

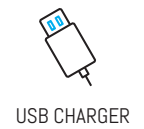

CONTROLLED VIA
SMARTPHONE APP

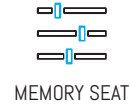

OPTIONS AND MEASUREMENTS

Recliner	980L x 1050D x 1050H
2 Seater	1890L x 1050D x 1050H
3 Seater	2200L x 1050D x 1050H

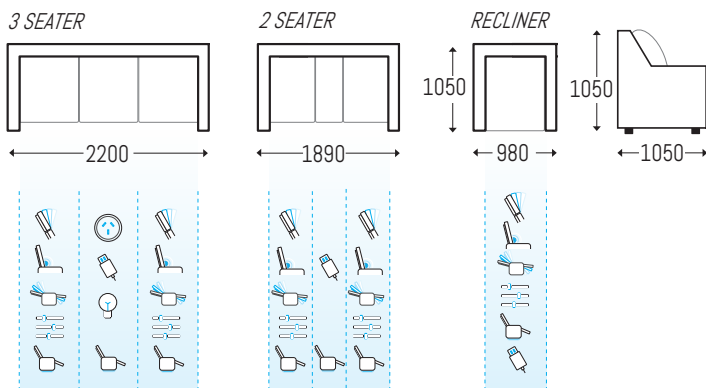

FEATURES & BENEFITS

- Use your smart phone to connect and control this lounge suite via the revolutionary Smart Comfort App.
- New Zealand Registered Design.
- Clever hidden storage is located in the armrests.
- Tray table on 2 Seater.
- USB charger in recliner arm and 2 Seat console.
- Power Recline, Power Headrest and Power Lumbar combine to provide the perfect seating position.
- Personalise base and cup holder light colours from a rainbow of options on the Smart Comfort App.
- The middle seat on the 3 Seater drops down to reveal reading lights, a table with cup holders and a charge station with USB and power sockets.
- Element Range.

SCAN TO LEARN MORE
ABOUT SMART COMFORT

OR VISIT BITLY/SMARTCOMFORTVID

LED lit Cup Holder Charge Station with USB & 240V on 3 Seater Convenient LED Reading Lights on 3 Seater

AVAILABLE IN VERITAS FABRIC

LIGHT GREY MID GREY DARK GRAPHITE

AVAILABLE IN GENESIS LEATHER

BLACK

ZIG ZAG SPRINGS	SUSTAINABLY HARVESTED WOOD	COMMERCIAL GRADE FABRIC	GENUINE LEATHER	STRUCTURAL WARRANTY	FOAM WARRANTY	MECHANICAL WARRANTY	LEATHER WARRANTY	ELECTRICAL WARRANTY	FABRIC WARRANTY